

KOP-FLEX®

Series H and Series HD Couplings Installation and Alignment Instructions

FORM

1912-01E
Revised
June 2016

⚠ WARNING

- Read and follow all instructions carefully.
- Disconnect and lock-out power before installation and maintenance. Working on or near energized equipment can result in severe injury or death.
- Do not operate equipment without guards in place. Exposed equipment can result in severe injury or death.

⚠ CAUTION

- Periodic inspections should be performed. Failure to perform proper maintenance can result in premature product failure and personal injury.

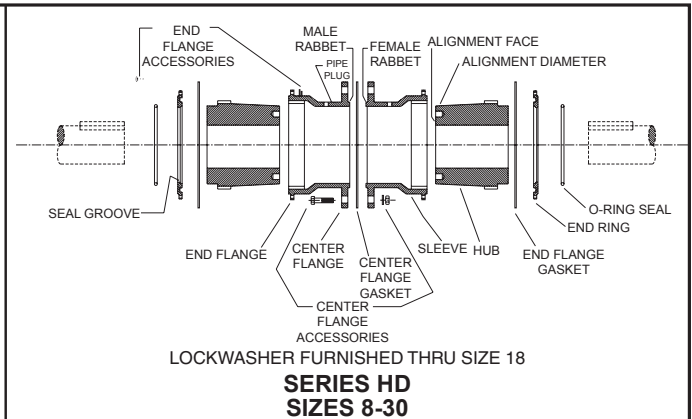
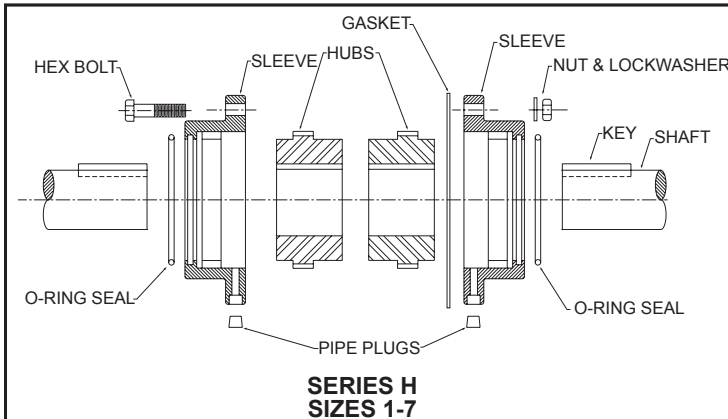

INSTALLATION and ALIGNMENT INSTRUCTIONS

These instructions generally apply to KOP-FLEX® Series H and Series HD couplings.

This sheet may be supplemented by Special Instructions supplied with the coupling for modifications and variations of these couplings. For dimensions, ratings, maximum bores, interference fits, and other technical information, please refer to Bulletin 2000.

CAUTION: when working on rotating equipment. Be sure to lock out the starting switch of the prime mover so the equipment cannot be started until work is complete, checked, and personnel are safely away.

MAINTENANCE and LUBRICATION

Lubricate the Series H and Series HD couplings only with grease. Use KOP-FLEX® KSG coupling grease or other grease meeting the minimum specifications shown. Do not use oil in Series H or HD couplings. Coupling lubrication is critical. The use of proper and sufficient lubrication is part of a successful installation. Lubricants should be checked to see the proper level is maintained and that the lubricant is free of contaminants.

In an average industrial application, the coupling should be checked for lubricant contamination and replenished with the proper volume every twelve months.

Conditions such as very slow speed, reversing drives, high heat and severe environments may require more frequent lubrication.

RECOMMENDED LUBRICANT

KOP-FLEX® KSG Coupling Grease

This grease is specifically compounded for standard couplings to provide improved lubrication and resistance to centrifugal separation. When KSG grease is used, lubrication intervals may be extended, based upon operating experience. Balanced couplings or others operating at speeds above 3500 rpm can benefit from KHP coupling grease. Both KSG and KHP coupling greases are available from Kop-Flex or authorized distributors of Kop-Flex power transmission products.

If the coupling is mounted on a reciprocating machine, or if recurrent reverse loading is experienced, a heavy viscous lubricant, similar to Texaco Crater Compound #0 or Gulf Lubecoat #0 may be required for damping characteristics.

OTHER GREASES

Alternate lubricating greases should equal or exceed the specifications for KOP-FLEX® KSG and KHP coupling greases. (Specification sheet 3532 is available upon request.) Greases other than KSG or KHP, should meet these minimum specifications:

Grade: NLGI #1
Base oil Viscosity: Min.:
3000 SSU at 100° F
160 SSU at 210° F
Dropping point, Min.: 190°F
Four Ball Wear, ASTM D-2266:
.500mm Maximum
Base oil content: 87% Minimum
K36 Factor, ASTM D-4425:
KSG: K36 = 8/24 = .33
Required:
Rust and Oxidation Inhibitors
E. P. Additives

The most reliable test of a suitable lubricant is often the result of user experience and satisfaction. If a lubricant has been known to sludge, separate into heavy components or dry out, consider the use of Kop-Flex greases or one meeting the minimum specifications.

REGAL™

Preparation:

NOTICE: that the Series H coupling sleeve has an integral end ring while the Series HD has a separate, bolted end ring.

Coat the sleeve teeth with coupling grease. Use a portion of the grease to coat the 'O' ring seals and install the seals into the groove of the Series H Sleeve, or the end ring of the Series HD coupling.

MAINTENANCE and LUBRICATION

For the Series H, place the coupling sleeves over the shaft end as shown in cover illustration.

For the Series HD, first place the end ring over the shaft.

If using a keyed connection apply a suitable anti-galling compound to the shaft. For keyless hub-to-shaft connections, follow the equipment manufacturers instructions.

Place keys in shaft keyways with a snug side-to-side fit, and slight clearance top to bottom. Clean the shaft and HUB. Straight bored hubs may be coated with a suitable anti-galling lubricant. Taper bored hubs must be installed without lubricant.

Expand HUB in an oven until the bore is substantially larger than the shaft diameter. Straight bored hubs are normally bored for an interference fit of approximately 0.0005 in/in of shaft diameter. For most values of interference, this will require a hub temperature of about 3000F (150°C). NEVER EXCEED 600°F (300°C).

WARNING! To avoid the risk of explosion, fire, damage to coupling and equipment, and/or injury to personnel, do not use an open flame or oil bath to expand the hub.

Remove HUB from oven and position quickly on shaft, with hub end flush with shaft end.

For normal applications, hubs are mounted with teeth away from end of shaft.

The Series H and HD couplings can accommodate increase hub separation by reverse mounting one, or both of the hubs. (See dimensions CI and CW in Table I and Table II.) Make sure the hub is mounted with the teeth in the correct location.

Properly orienting the hubs, slip them over the shafts and keys. Hub faces are normally mounted flush with the shaft end.

On bolted end ring couplings such as the Series HD, the sleeves are bolted to the end rings after placing the gasket between the flanges.

MAINTENANCE and LUBRICATION

Select the unheated taper bored hub. Mount the hub hand tight on its shaft and lightly rap it with a soft mallet to establish the initial line-to-line fit. Draw the hub up an additional Distance to obtain the desired interference fit for the connection. In some cases the hub may require heating to achieve desired fit.

(The required amount of axial movement is dependent upon the bore diameter and taper angle.)

Install the hub retention means (locknut, etc.) provided with the shaft, and securely lock the retainer into place. For most installations, the hub face will project lightly beyond the shaft end after hub pull-up.

CHECK ANGULAR ALIGNMENT

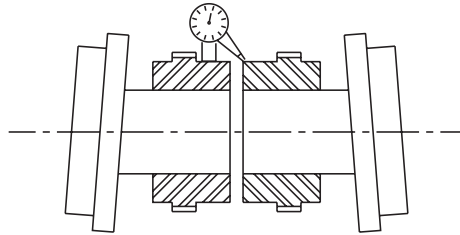

For normal hub separation, use a feeler gauge at 4 points 90° apart, or for best accuracy, a dial indicator.

Position machines to obtain best alignment. Normal variation should not exceed .001 inches (0.025mm) times coupling size. Maintain correct hub separation referring to the "C" dimension shown in tabulations on page 4.

For Greater hub separation than standard (such as spacer and floating shaft couplings), use micrometers or other suitable alignment fixtures to span the separation and measure the four 90° points.

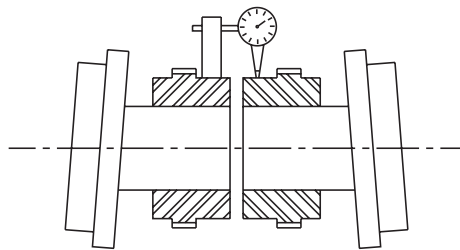

Note: For maximum coupling life, the Instrument Method of coupling alignment is recommended.

Attach a dial indicator bracket to one hub with dial indicator probe contacting the opposite hub's alignment surface. Rotate the hub ON WHICH THE DIAL INDICATOR IS ATTACHED, and take readings at 4 points 90° apart. The offset (TIR) should be less than .002 inches times the coupling size. For greater hub separation than (such as spacer or floating shaft couplings) use suitable fixtures to span the separation and measure the four 90° points. Shim either machine until best possible alignment is obtained.

Recheck angular alignment and hub separation.

OFFSET ALIGNMENT VISUAL METHOD

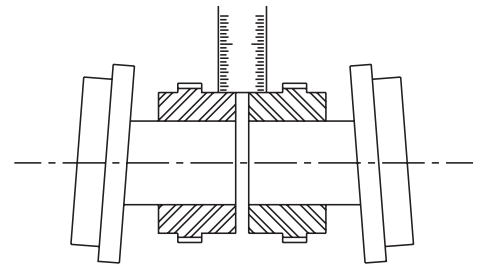

Shim one machine and align shafts using a straight edge until it appears to be at right angles to the shafts. Repeat at three additional points 90° apart.

Recheck angular alignment and hub separation.

COUPLING ASSEMBLY

Check to insure the center flange gasket (or O-ring) is not damaged. Clean the flange faces and place the gasket in place. For spacer couplings or other arrangements, a gasket must be placed between each set of flanges.

Draw flanges together, positioning lube holes 90° apart.

Align the gasket with the flange bolt holes, insert the fitted bolts, lockwashers and nuts. Tighten all fasteners to the torque value shown on page 4.

n.

Remove two fittings 1800 apart. Rotate the coupling to place the bottom hole 450 off horizontal. Pump lubricant into the top hole until excess appears at the bottom hole. Sufficient lubricant has now been added. (Hand packing of grease in each half of the coupling is recommended.)

Do not attempt to fill the coupling without venting the interior; and air lock can result in incomplete filling or in damage to the 'O' ring seal.

After lubrication, tighten lube plugs to the specified torque value shown on page 4.

Note: Spacer; limited end float; floating shaft couplings, and some other styles, require each end to be separately lubricated. Do not fill the interior of spacer coupling arrangements. Lubricant capacities for each size and coupling style are given on page 4. One-half this amount should be placed in each coupling half.

DYNAMICALLY BALANCED COUPLINGS

In addition to the previous instructions, certain other precautions must be followed to insure coupling dynamic balance at assembly.

1. Replace each nut, and lockwasher on its own bolt as they have been weight balanced as a set. The set can be used in any bolt hole.
2. Fit the shaft keys precisely to fill the keyway with a tight fit only on the sides. Key weight should equal the weight of metal removed from shaft and hub keyways.
3. Position each sleeve with its hub; noting any match marks on either the sleeve or hub. Keep match marks in line as final assembly is completed.
4. Position all other parts such as spacer, floating shaft, etc., properly aligning any match marks.
5. Lubricate the coupling.

Note: Use an adapter plate only with half-coupling of the same serial number.

FINISH BORING and KEYWAYS

Coupling hubs are often furnished with a "rough stock bore." This rough bore is not necessarily concentric to other hub diameters.

To prepare for boring, set up and indicate the hub as shown by the illustration.

Bore sizing and recommended fit: Finish bore size should be based on the actual shaft dimension measured, regardless of whether straight or taper shaft.

A light interference fit based on a nominal interference of .0005 in. per inch of shaft diameter is suggested, or refer to published AGMA standards.

Do not exceed an interference fit of .0012 per inch of shaft diameter for the Series H, or for the Series HD.

Alternate fits:

If other than a light interference fit is desired, please consult the published AGMA boring and keyway standards, or contact our engineering department for specific recommendations.

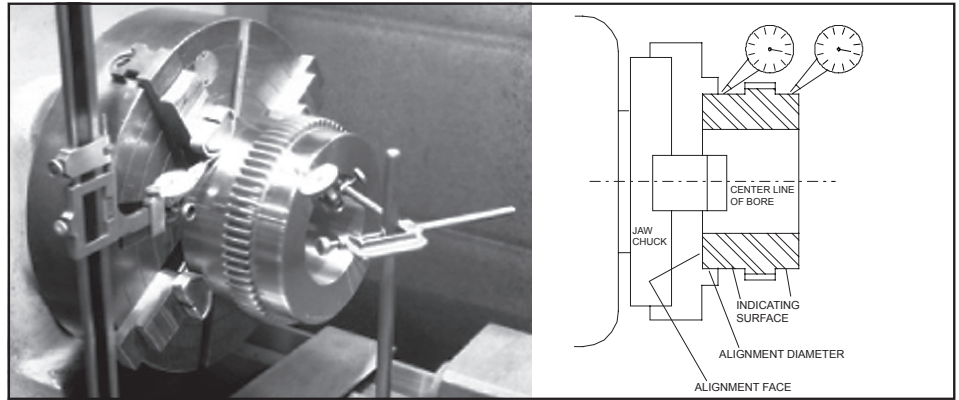

The alignment diameter of the hub should be chucked in the boring lathe and dial indicated as shown, so that run-out is as near zero as possible. It is essential that the finished bore be concentric with the two indicating surfaces.

KEYWAYS

Keyways should be cut to give a tight fit on the sides, and slight clearance over or under the key. Keyways should not have sharp corners. Refer to published AGMA standards for specific dimensioning of coupling bores and keyways.

Important Safety Instructions Before start-up . . .

For reasons of safety and to extend shaft coupling life, follow these requirements.

1. Coupling guards protect personnel. All couplings must be covered with a guard as per OSHA requirements
2. Recheck alignment after all foundation bolts and mechanical connections are tightened.
3. Make sure all fasteners are properly installed and tightened.
4. Take the time to double check your work.
5. Only authorized Kop-Flex replacement parts are to be used.
6. Call Kop-Flex for any clarification or questions.

SERIES H

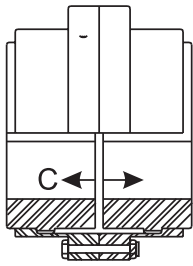

STANDARD COUPLING

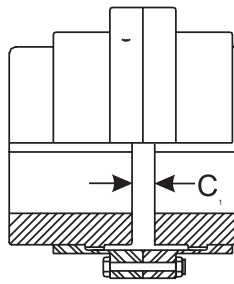

**STANDARD COUPLING
(One Hub Reversed)**

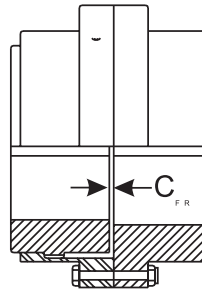

FLEX-RIGID COUPLING

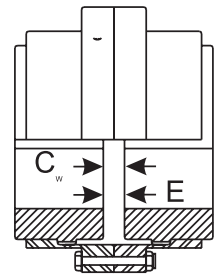

**STANDARD COUPLING
(Both Hubs Reversed)**

TABLE I

COUPLING SIZE		1H	1 1/2 H	2H	2 1/2 H	3H	3 1/2 H	4H	4 1/2 H	5H	5 1/2 H	6H	7H
Grease Capacity Full Flex	Lbs.-Oz.	0-2	0-3	0-5	0-8	0-15	1-7	2-0	3-3	5-0	6-2	8-0	13-0
Flex-Rigid	Lbs.-Oz.	0-1	0-2	0-3	0-4	0-8	0-12	1-0	1-10	2-8	3-1	4-0	6-8
Spacer Couplings (All Standards Lengths)	Lbs.-Oz.	0-3	0-5	0-8	0-12	1-7	2-3	3-0	4-13	7-8	9-3	12-0	19-8
Hub Separation "C" Full-Flex	Inch	1/8	1/8	1/8	3/16	3/16	1/4	1/4	5/16	5/16	5/16	5/16	3/8
Hub Separation "C ₁ " One Hub Reversed	Inch	3/16	5/16	9/16	15/32	29/32	1 1/16	1 1/4	1 7/16	1 31/32	2 3/32	2 11/32	2 13/16
Hub Separation "C _w " Both Hubs Reversed	Inch	1/4	1/2	1	3/4	1 5/8	1 7/8	2 1/4	2 9/16	3 5/8	3 7/8	4 3/8	5 1/4
Hub Separation "C _{FR} " Flex-Rigid	Inch	5/32	5/32	5/32	3/16	3/16	7/32	5/16	11/32	11/32	11/32	11/32	7/16
Hub Separation "E _{FR} " Flex-Rigid													
Bolt Tightening Torque Shrouded Bolts	Lb.-Ft.	6	23	23	55	55	110	110	110	195	-	-	-
Bolt Tightening Torque Exposed Bolts	Lb.-Ft.	5	20	50	100	100	175	175	175	165	165	165	250
Lube Plug Tightening Torque		20 (Lb. Ft.)					50 (Lb. Ft.)						
"O" Ring Commercial ⁽¹⁾ Designation ARP568-		229	235	1345	352	358	439	444	446	448	450	452	456

Note (1) EXAMPLE: ARP568-229

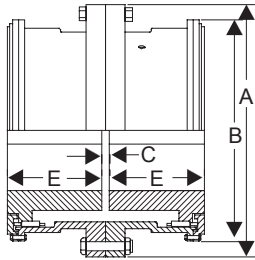

STANDARD FULL-FLEX

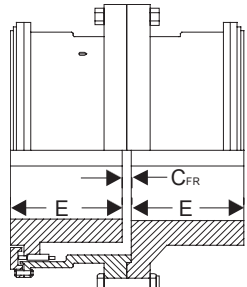

FLEX RIGID

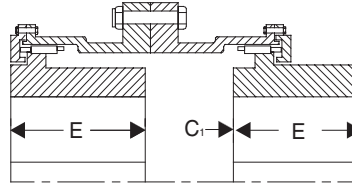

ONE HUB REVERSED

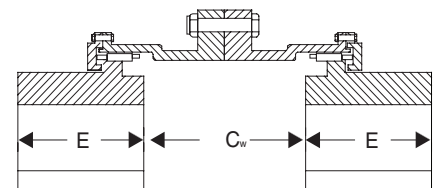

TWO HUB REVERSED

TABLE II

COUPLING SIZE		8	9	10	11	12	13	14	15	16	18	20	22	24	26	28	30
Hub Separation	C (inches)	3/8	1/2	1/2	1/2	1/2	3/4	3/4	3/4	1							
	C _{fr} (inches)	1/2	9/16	5/8	5/8	5/8	3/4	3/4	3/4	1	1	1	1 1/8				
	E _{fr} (inches)																
Lubricant Capacity	Full-Flex Weight (lbs.)	14	23	28	37	42	48	56	62	73	88	121	147	173	191	206	221
	Flex-Rigid Weight (lbs)	7	11.5	14	18.5	21	24	28	31	36.5	44	60.5	73.5	86.5	99.5	103	111
Center Flange	Diameter "A" (inches)	23 1/4	26	28	30 1/2	33	35 3/4	38	40 1/2	43	47 1/2	53 1/2	59	64 1/4	68 1/2	73 3/4	78
	Bolt Torque (Lb. Ft.)	350	500	660	870		1100	1370		2060		3010	4120	5600		7390	
End Flange	Diameter "B" (inches)	20 1/2	23	25 1/8	27 5/16	29 13/16	32	34 1/8	36 3/4	38 7/8	43 1/8	48 3/8	52 7/8	52 3/8	61 5/8	66 3/16	70 11/16
	Bolt Torque (Lb. Ft.)	50		100	175			165			250		350				
Lube Plug Tightening Torque		350 (Lb. Ft.)										575 (Lb. Ft.)					
"O" Ring, Kop-Flex P/N WA		13561	27405	27408	27412	PN WA309											
						-82	-83	-84	-85	-86	-87	-88	-89	-90	-91	-92	-93

Note (1) EXAMPLE: ARP568-229

